

Graduate Operating Systems

Spring 2022

1

Locality of Reference

- Temporal
 - Recently referenced items are likely to be reused
- Spatial
 - Items with nearby addresses tend to be referenced close together in time
- Data
 - Walking through an array or a matrix
 - Referencing sum in each iteration
- Instructions
 - Reference instructions in sequence
 - Loops

```
sum = 0;
for (i = 0; i < n; i++)
sum += a[i];
return sum;
```

2

Good or Bad Locality?

```
int sum_array_rows(int a[M][N])
{
    int i, j, sum = 0;

    for (i = 0; i < M; i++)
        for (j = 0; j < N; j++)
            sum += a[i][j];
    return sum;
}
```

```
int sum_array_cols(int a[M][N])
{
    int i, j, sum = 0;

    for (j = 0; j < N; j++)
        for (i = 0; i < M; i++)
            sum += a[i][j];
    return sum;
}
```

3

Good or Bad Locality?

```
int sum_array_3d(int a[M][N][N])
{
    int i, j, k, sum = 0;

    for (i = 0; i < M; i++)
        for (j = 0; j < N; j++)
            for (k = 0; k < N; k++)
                sum += a[k][i][j];
    return sum;
}
```

4

Paper "Multics"

- Multiplexed Information and Computing Service

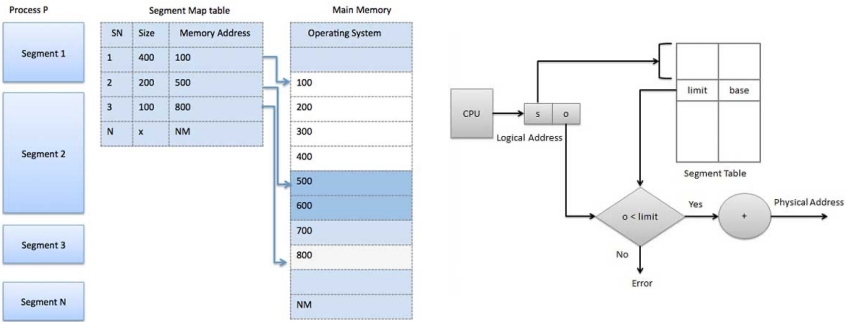

5

Paper "Multics"

- Paging

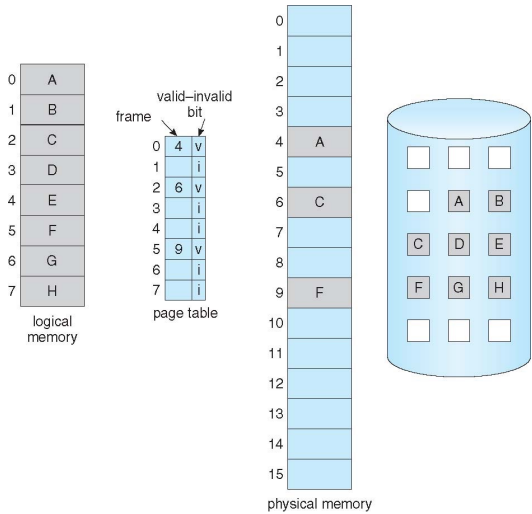

6

Paper “Multics”

- What is the motivation behind segmentation?
- What is the motivation behind paging?
- Demand paging
- Machine independence
- Descriptor segment (DS)
- Descriptor base register (DBR)
- Segment descriptor word (SDW)
- Segmentation fault
- Page fault

7

Paper “Multics”

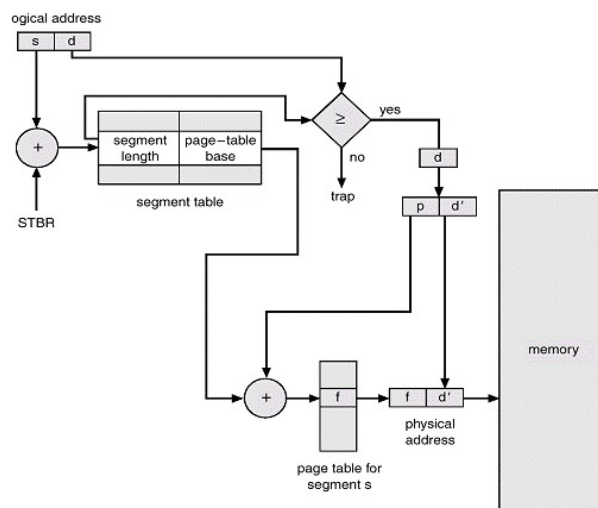

8